

BIG BLASTER® XHV Air Cannon

2-Inch Valve



Benefits

- Effective Boost to Solids Flow**
 High-velocity discharge of stored air enhances material movement.
- Withstands High Temperatures**
 Designed for use on cement kiln pre-heaters and other "hot" applications.
- Minimum Maintenance**
 Short piston stroke reduces wear and holds down maintenance costs.
- 200,000 Firings Guaranteed**

BIG BLASTER® XHV Air Cannons supply a quiet but powerful discharge of plant compressed air to dislodge material buildups and enhance the flow of bulk solids.

BIG BLASTER® XHV Air Cannons provide effective performance on high-temperature applications and the most challenging materials. Low maintenance requirements and high-velocity discharge.

BIG BLASTER® XHV Air Cannons are designed for severe-duty applications where exposure to elevated service temperatures and harsh gases can affect performance. They have proven successful in applications outside cement kiln pre-heaters where interior temperatures reach up to 2500°F (1371°C).

Performance Data

Model	Fill Time* seconds	Discharge Time ** seconds	Noise ***		
			@ 80 psi (5.5 bar) db	@ 90 psi (6.2 bar) db	@ 100 psi (6.9 bar) db
BB2-8-12	7.38	0.09	65	67	68
BB2-8-20	12.35	0.15	70	71	71

* Standard fill time to fully charge to supply pressure at 90 psi (6.2 bar) with minimum of 50 cfm (1416 l/min) delivery.

** Length of time to fully discharge tank pressure at 90 psi (6.2 bar).

*** Noise measure at a distance of 4 feet (1.2 meters) for discharge into 6 tons (5442 kg) of material with bulk density of 105 lb per cubic foot (1,680 kg per cubic meter).

Nomenclature

Model numbers are composed of the prefix BB, followed by three numbers representing critical dimensions (in inches) of the unit. The first number is the diameter of the discharge, the second number is tank diameter, and the third set of numbers specifies the tank length.

BB2-8-12 XHV

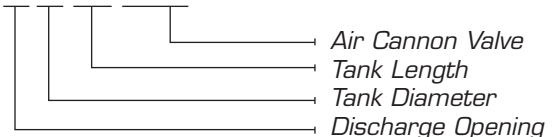

BIG BLASTER® XHV Air Cannon—2-Inch Valve

Dimensions—in. (mm)

Model	P/N	A	B	C	D	E	F	G	H	J*	K
BB2-8-12 XHV	35859-0812	12 (305)	8 (203)	21 (533)	4.69 (119)	11.75 (298)	4 (102)	4 (102)	8.8 (224)	1	2
BB2-8-20 XHV	35859-0820	20 (508)	8 (203)	29 (737)	4.69 (119)	11.75 (298)	4 (102)	4 (102)	8.8 (224)	1	2

* NPT—National Pipe Thread

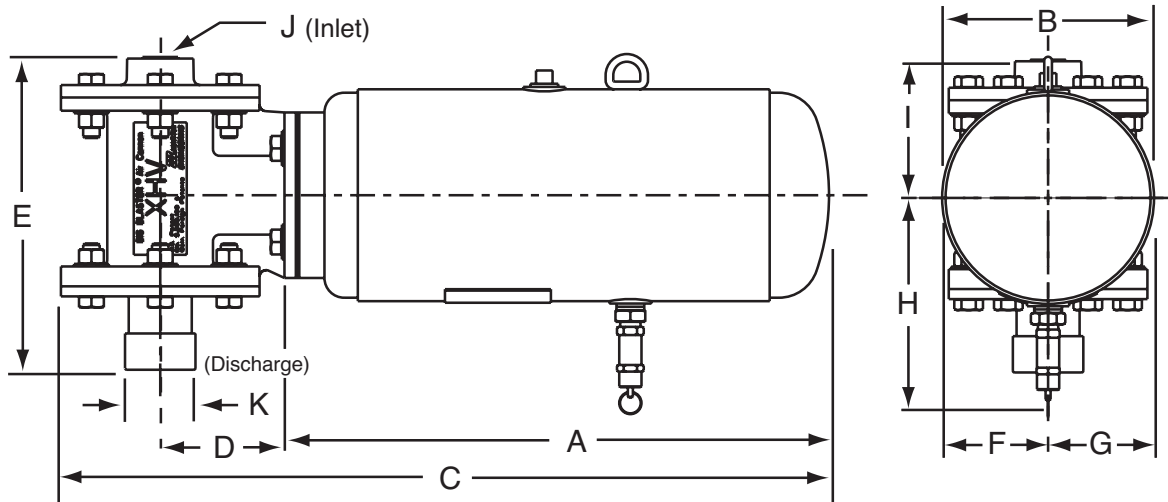

Air Volume In Cubic Feet (Liters) Free Air

Air Pressure psi (bar)	BB2-8-12 XHV-H	BB2-8-20 XHV-H
0 (0)	0.31 (9)	0.52 (15)
40 (2.8)	0.84 (24)	1.41 (40)
50 (3.4)	1.05 (30)	1.77 (50)
60 (4.1)	1.27 (36)	2.12 (60)
70 (4.8)	1.48 (42)	2.48 (70)
75 (5.2)	1.58 (45)	2.66 (75)
80 (5.5)	1.69 (48)	2.83 (80)
85 (5.9)	1.80 (51)	3.00 (85)
90 (6.2)	1.90 (54)	3.18 (90)
95 (6.5)	2.00 (57)	3.36 (95)
100 (6.9)	2.11 (60)	3.54 (100)
110 (7.6)	2.32 (66)	3.89 (110)
120 (8.3)	2.53 (72)	4.24 (120)

Guaranteed engineering and installation of BIG BLASTER® XHV Air Cannon Systems is available from Martin Services. Maintenance is also available from Martin Service Technicians.

Certified drawings of air cannon system installations are available from the Engineering Department at Martin Engineering.

Martin Engineering recommends the walls of all storage vessels be cleaned prior to the installation of any BIG BLASTER® Air Cannon System.

For further information, contact Martin Engineering at 800-544-2947 or visit our website at www.martin-eng.com.



Martin Engineering USA
One Martin Place
Neponset, IL 61345-9766 USA
800 544 2947 or 309 852 2384
Fax 800 814 1553
www.martin-eng.com

Subject to change without prior notice.
Patents and patents pendings, ® registered trademark of Martin Engineering Company in the U.S. and other select locations.
Additional information can be obtained at www.martin-eng.com/trademarks.

QUALITY MANAGEMENT SYSTEM
CERTIFIED BY DNV
ISO 9001:2008