

BIG BLASTER® XHV Air Cannon

4-Inch Valve



Benefits

- **Effective Boost to Solids Flow**
High-velocity discharge of stored air enhances material movement.
- **Minimum Maintenance**
Short piston stroke reduces wear and holds down maintenance costs.
- **Withstands High Temperatures**
Designed for use on cement kiln pre-heaters and other “hot” applications.
- **200,000 Firings Guaranteed**

BIG BLASTER® XHV Air Cannons supply a quiet but powerful discharge of plant compressed air to dislodge material buildups and enhance the flow of bulk solids.

BIG BLASTER® XHV Air Cannons provide effective performance on high-temperature applications and the most challenging materials. Low maintenance requirements and high-velocity discharge.

BIG BLASTER® XHV Air Cannons are designed for severe-duty applications where exposure to elevated service temperatures and harsh gases can affect performance. They have proven successful in applications outside cement kiln pre-heaters where interior temperatures reach up to 2500°F (1371°C).

Performance Data

Model	Fill Time* seconds	Discharge Time** seconds	Noise***		
			@ 80 psi (5.5 bar) db	@ 90 psi (6.2 bar) db	@ 100 psi (6.9 bar) db
BB4-12-28	40.23	0.12	75	80	80
BB4-20-30	114.44	0.31	80	82	82
BB4-24-48	272.00	0.79	82	83	84
BB4-30-60	531.57	1.54	83	84	86

* Standard fill time to fully charge to supply pressure at 90 psi (6.2 bar) with minimum of 50 cfm (1416 l/min) delivery.

** Length of time to fully discharge tank pressure at 90 psi (6.2 bar).

*** Noise measure at a distance of 4 feet (1.2 meters) for discharge into 6 tons (5442 kg) of material with bulk density of 105 lb per cubic foot (1,680 kg per cubic meter).

Nomenclature

Model numbers are composed of the prefix BB, followed by three numbers representing critical dimensions (in inches) of the unit. The first number is the diameter of the discharge, the second number is tank diameter, and the third set of numbers specifies the tank length.

BB4-12-28 XHV

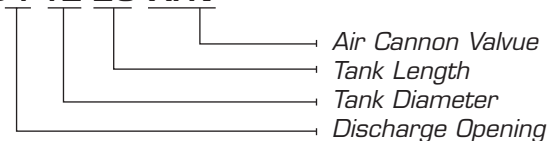

TECHNICAL DATA SHEET

BIG BLASTER® Air Cannon—4-Inch Valve

Dimensions—in. (mm)

* NPT—National Pipe Thread

Model	P/N	A	B	C	D	E	F	G	H	I	J*	K
BB4-12-28	35132-1228	28 (711)	12 (305)	41.65 (1058)	8 (203)	18.5 (470)	7.5 (190)	6.5 (165)	10.6 (269)	6 (152)	1	4
BB4-20-30	35132-2030	30 (762)	20 (508)	43.65 (1109)	8 (203)	18.5 (470)	11.5 (292)	10.5 (267)	14.6 (371)	10 (254)	1	4
BB4-24-48	35132-2448	48 (1219)	24 (610)	61.65 (1566)	8 (203)	18.5 (470)	13.5 (343)	12.5 (317)	16.6 (422)	12 (305)	1	4
BB4-30-60	35132-3060	60 (1524)	30 (762)	73.65 (1871)	8 (203)	18.5 (470)	31.5 (800)	15.5 (394)	19.6 (498)	15 (381)	1	4

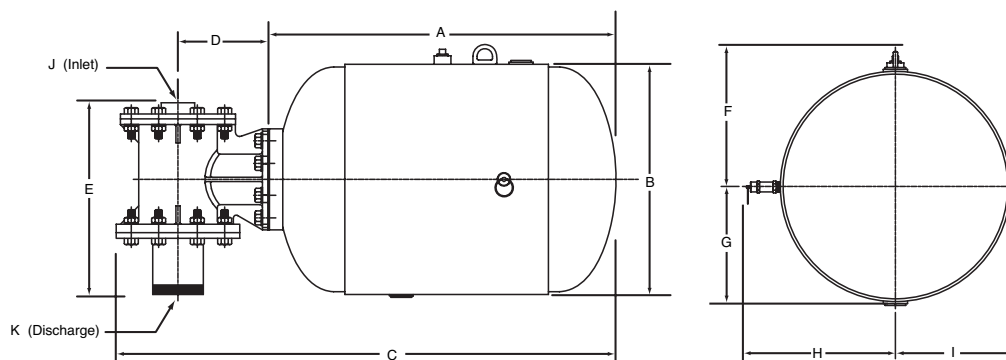

Air Volume In ft³ (Liters) Free Air

Air Pressure psi (bar)	BB4-XX-XX XHV			
	12-28	20-30	24-48	30-60
0 (0)	1.70 (48)	4.48 (137)	11.51 (326)	22.49 (637)
40 (2.8)	4.63 (131)	13.17 (373)	31.32 (887)	61.20 (1733)
50 (3.4)	5.78 (164)	16.46 (466)	39.15 (1109)	76.50 (2166)
60 (4.1)	6.94 (196)	19.76 (560)	46.98 (1330)	91.80 (2600)
70 (4.8)	8.10 (229)	23.03 (652)	54.81 (1552)	107.10 (3033)
75 (5.2)	8.67 (246)	24.69 (699)	58.72 (1663)	114.75 (3250)
80 (5.5)	9.25 (262)	26.34 (746)	62.64 (1774)	122.40 (3466)
85 (5.9)	9.83 (278)	27.99 (793)	66.55 (1885)	130.00 (3683)
90 (6.2)	10.41 (295)	29.63 (839)	70.47 (1996)	137.70 (3900)
95 (6.5)	11.00 (311)	31.28 (886)	74.38 (2107)	145.34 (4116)
100 (6.9)	11.57 (328)	32.93 (933)	78.30 (2121)	153.00 (4333)
110 (7.6)	12.72 (360)	36.22 (1026)	86.13 (2439)	168.30 (4766)
120 (8.3)	13.88 (370)	39.51 (1119)	93.96 (2661)	183.60 (5200)

Guaranteed engineering and installation of BIG BLASTER® XHV Air Cannon Systems is available from Martin Services. Maintenance is also available from Martin Service Technicians.

Certified drawings of air cannon system installations are available from the Engineering Department at Martin Engineering.

Martin Engineering recommends the walls of all storage vessels be cleaned prior to the installation of any BIG BLASTER® Air Cannon System.

For further information, contact Martin Engineering at 1-800-544-2947 or visit our website at www.martin-eng.com.



Martin Engineering USA
 One Martin Place
 Neponset, IL 61345-9766 USA
 800 544 2947 or 309 852 2384
 Fax 800 814 1553
www.martin-eng.com

Subject to change without prior notice.
 Patents and patents pendings, ® registered trademark of Martin Engineering Company in the U.S. and other select locations.
 Additional information can be obtained at www.martin-eng.com/trademarks.

QUALITY MANAGEMENT SYSTEM
 CERTIFIED BY DNV
ISO 9001:2008

Problem Solved™

Form No. L3544-07/11
 © Martin Engineering Company 2011