



MARTIN®

Sonic Horn Controller

[Go to MARTIN® Sonic Horn Controller web page](#)



Operator's Manual
M3859

Important

MARTIN ENGINEERING HEREBY DISCLAIMS ANY LIABILITY FOR: DAMAGE DUE TO CONTAMINATION OF THE MATERIAL; USER'S FAILURE TO INSPECT, MAINTAIN AND TAKE REASONABLE CARE OF THE EQUIPMENT; INJURIES OR DAMAGE RESULTING FROM USE OR APPLICATION OF THIS PRODUCT CONTRARY TO INSTRUCTIONS AND SPECIFICATIONS CONTAINED HEREIN. MARTIN ENGINEERING'S LIABILITY SHALL BE LIMITED TO REPAIR OR REPLACEMENT OF EQUIPMENT SHOWN TO BE DEFECTIVE.

Observe all safety rules given herein along with owner and Government standards and regulations. Know and understand lockout/tagout procedures as defined by American National Standards Institute (ANSI) z244.1-1982, *American National Standard for Personnel Protection - Lockout/Tagout of Energy Sources - Minimum Safety Requirements* and Occupational Safety and Health Administration (OSHA) Federal Register, Part IV, 29 CFR Part 1910, *Control of Hazardous Energy Source (Lockout/Tagout); Final Rule*.

The following symbols may be used in this manual:



Danger: Immediate hazards that will result in severe personal injury or death.



Warning: Hazards or unsafe practices that could result in personal injury.



Caution: Hazards or unsafe practices that could result in product or property damages.



Important: Instructions that must be followed to ensure proper installation/operation of equipment.



Note: General statements to assist the reader.

Table of Contents

Section	Page
List of Figures	ii
Introduction	1
General	1
Overview of controller operation	1
References	2
Safety	2
Material required	2
Before Installing Controller	3
Installing Controller	4
Mounting enclosure	4
Wiring sonic horn solenoids to controller	5
Wiring external flow switch to controller	6
After Installing Controller	7
Manually cycling sonic horns	7
Programming Controller	8
Setting on time	10
Setting off time	11
Parts Numbers	12
Appendix: MARTIN [®] Sonic Horn Controller Electrical Schematic	A-1

List of Figures

Figure	Title	Page
1	Flow switch inputs open, controller disabled	2
2	Terminal Block Layout	5
3	Sonic Horn Inputs	6
4	MARTIN® Sonic Horn Controller Door	7
5	Off Time Selection	8
6	Selecting On Time	10
7	Setting On Time	10
8	Selecting Off Time	11
9	Setting Off Time	11
10	MARTIN® Sonic Horn Controller, P/N 38901-S	12
11	MARTIN® Sonic Horn Controller Dimensions	13

General

The MARTIN[®] Sonic Horn Controller is a reliable, practical system for firing MARTIN[®] Sonic Horns at predetermined intervals. The controller uses programmable logic to energize the sonic horns' solenoids. It reduces the chance for human error and is expandable to control multiple sonic horns in several structures where material flow problems exist.

The controller is used to cycle horns in a timed sequence. It is available with up to 10 outputs.

Each controller has an adjustable on time and adjustable off times. Manual override selector knobs are mounted on the outside of the enclosure.

Overview of controller operation

The controller can be used to cycle sonic horns in three ways:

- Manually cycle individual horns using the manual override selector knobs.
- Automatically cycle all horns in a timed sequence.
- Automatically cycle all horns in a timed sequence when activated by an external switch.

(An example of an external switch is a paddle-type flow switch that monitors flow of material as shown in Figure 1. When material stops flowing from the hopper, the flow switch inputs are closed and the controller is enabled to begin the cycling sequence. Whenever material is flowing from the hopper, the flow switch inputs are opened and the controller is disabled; the cycling sequence is deactivated.)

To manually cycle individual horns, it is not necessary to program the controller. The selected horn cycles when activated by the selector knobs on the outside of the controller.

To automatically cycle all horns in a timed sequence, the controller must be programmed for the desired number of sonic horns to sequence (from 1 up to 10 sonic horns) and the desired off-time (the length of time between each horn cycle).

To automatically cycle all horns in a timed sequence when activated by an external (flow) switch, the controller must be programmed as described above, and the switch must be connected to the controller as follows:

- When connected to the controller's ENABLE terminal block, the horns will cycle in the programmed sequence (e.g., horns 1 through 10 cycle in sequence) until the switch disables the controller and deactivates the cycling sequence. When the switch enables the controller again (activates cycling), the controller resets the sequence to begin with horn 1 (e.g., if the switch disabled the controller after cycling horn 3, the sequence will start by cycling horn 1 the next time it is activated).

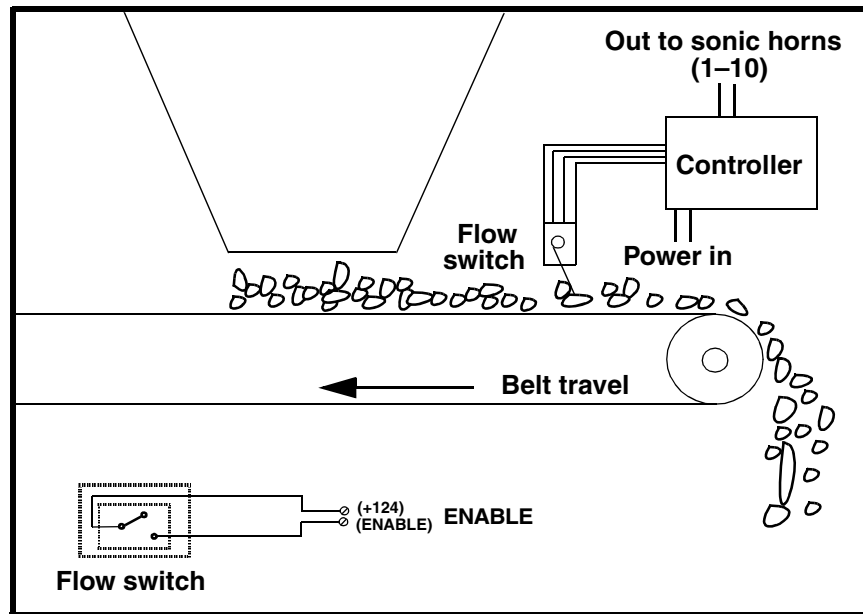

Figure 1. Flow switch inputs open, controller disabled

References

The following documents are referenced in this manual:

- American National Standards Institute (ANSI) z244.1-1982, *American National Standard for Personnel Protection - Lockout/Tagout of Energy Sources - Minimum Safety Requirements*, American National Standards Institute, Inc., 1430 Broadway, New York, NY 10018.
- Federal Register, Volume 54, Number 169, Part IV, 29 CFR Part 1910, *Control of Hazardous Energy Source (Lockout/Tagout); Final Rule*, Department of Labor, Occupational Safety and Health Administration (OSHA), 32nd Floor, Room 3244, 230 South Dearborn Street, Chicago, Illinois 60604.
- *The National Electrical Code (NEC)*, National Fire Protection Association, 1 Batterymarch Park, P.O. Box 9101, Quincy, MA 02269-9101.

Safety

All safety rules defined in the above documents and all owner/employer safety rules must be strictly followed when working on this equipment.

Material required

Only standard hand tools are required to install this equipment.

Before Installing Controller

1. Remove controller from shipping box.
2. If anything is missing or damaged, contact Martin Engineering or a representative. Keep any damaged goods subject to examination.



⚠ WARNING

Before installing equipment, lock out/tag out energy source to hopper, conveyor, and/or conveyor accessories.

3. Turn off and lock out/tag out energy source according to ANSI standards (see “References”).

⚠ WARNING

If equipment will be installed in an enclosed area, test gas level or dust content before using a cutting torch or welding. Using a cutting torch or welding in an area with gas or dust may cause an explosion.

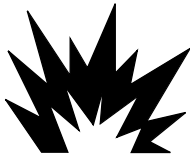

4. If using a cutting torch or welding, test atmosphere for gas level or dust content.

Installing Controller

To install the controller, follow the procedures in this manual corresponding to the following steps:

1. Mount the controller enclosure on a wall.
2. Wire individual sonic horn solenoids to controller or, if sonic horns are wired to a solenoid enclosure, wire solenoid enclosure to controller.
3. If using an external flow switch, wire dry contact to controller.

Mounting enclosure

⚠ WARNING

All electrical work must be done to National Electrical Code (NEC) standards.

1. Determine location for controller.

⚠ CAUTION

Do not mount controller in area subject to shock, vibration, temperatures exceeding 130°F (55°C), or explosion. Damage to controller circuitry could result.

2. Mount onto wall with fasteners.
3. Drill conduit holes in controller enclosure for solenoid and power wires. Use care not to damage internal components. Drill in most weather-proof location available on enclosure.
4. Using electrical connectors, route wires from solenoid valves to controller enclosure.

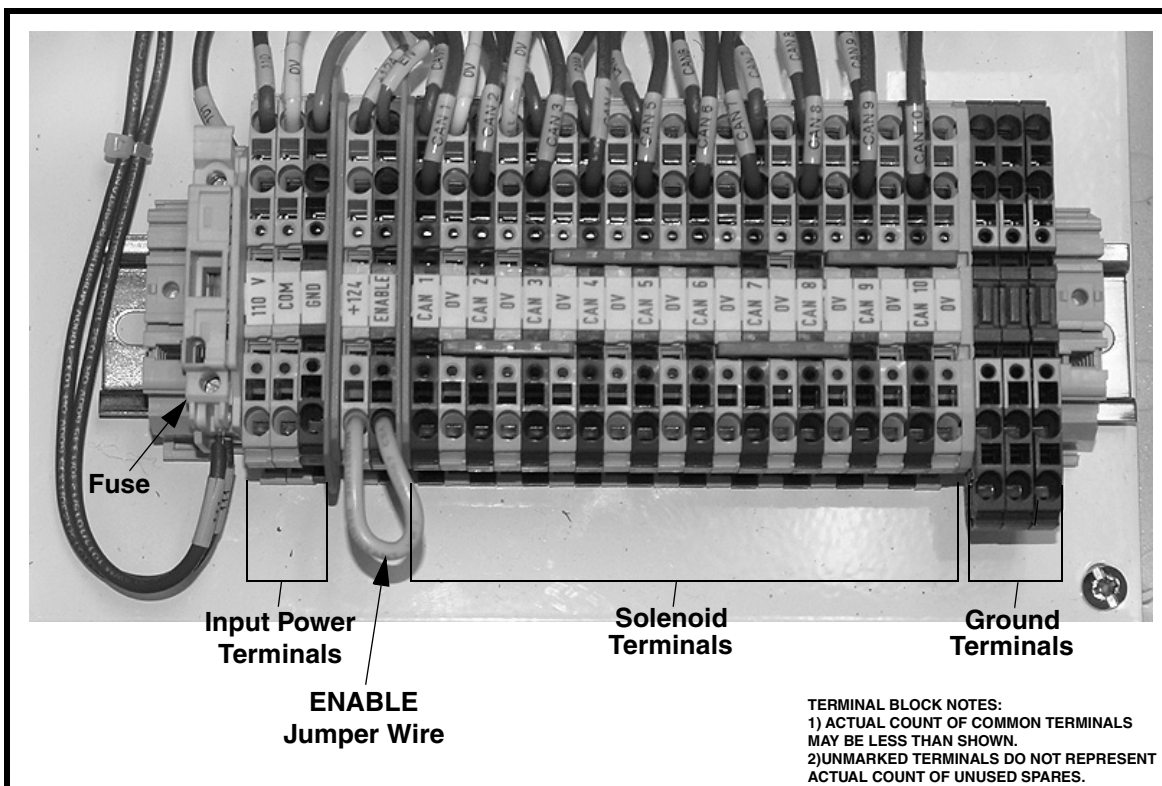

Figure 2. Terminal Block Layout

Wiring sonic horn solenoids to controller

NOTE

Only wiring required is power wire to controller and N terminals on controller's printed terminal strip.

1. Connect wires from sonic horn solenoids to terminal strip outputs 1 through 10 and N terminals (see Figure 2). Connect number 1 solenoid to 1 supply and N, number 2 solenoid to 2 supply and N, etc. Continue until all solenoids are connected.
2. Connect ground wire from each solenoid to controller enclosure. Route power wire (115 VAC, 60 Hz) into controller enclosure.
3. Connect power safety ground wire to terminal block labeled GND.
4. Connect power wires to terminal blocks labeled 110V and COM. Connect phase to 110V and neutral to COM.
5. Ensure ENABLE jumper is in place.

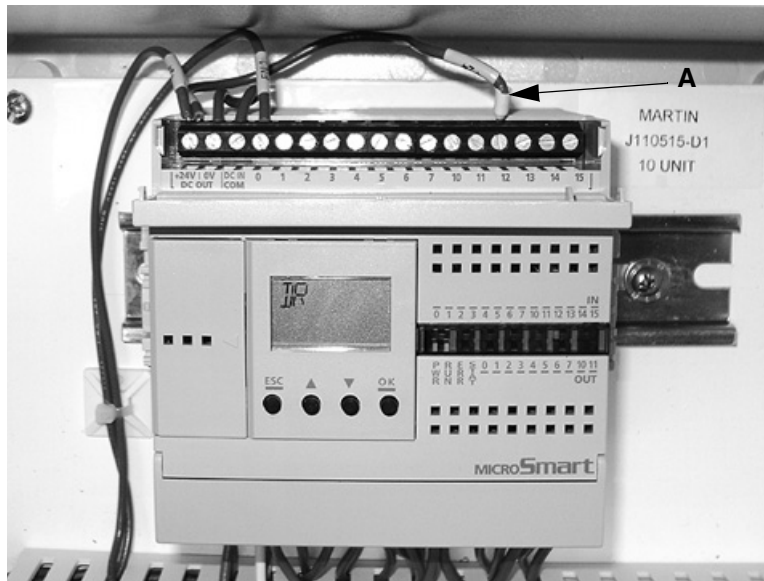

Figure 3. Sonic Horn Inputs

NOTE

PLC uses an octal numeral system.

6. Determine number of sonic horns to be controlled.
7. Move “SELECT” wire (A) to terminal number (1—12) that corresponds with number of sonic horns to be controlled. For example, to use four sonic horns connect “SELECT” wire to input 4.
8. If using an external flow switch, follow the procedure under “Wiring external flow switch to controller.” If not, follow the procedures under “After installing controller.”

Wiring external flow switch to controller

▲ WARNING

Before making any connections, lock out/tag out electrical supply to controller according to ANSI standards (see “References”).

NOTE

ENABLE always resets the controller to sonic horn 1 while material flows. See “Overview of controller operation” under “Introduction” for more information.

2. To use ENABLE, do the following:
 - a. Remove factory-installed jumpers between ENABLE terminal blocks.
 - b. Connect external flow switch dry contact to ENABLE terminals.
 - c. Connect external flow switch ground to controller.

After Installing Controller

Manually cycling sonic horns

1. To manually cycle sonic horns 1 through 10, turn selector knob on door of controller enclosure to number of horn you wish to cycle. Turn HAND-OFF-AUTO knob to HAND (see Figure 4), hold to cycle horn, and release. (Selected horn will cycle and knob will return to OFF automatically.)
2. When finished with manual cycles, return selector knob to 0. (This disconnects the manual mode, and prevents accidental cycling if the HAND-OFF-AUTO switch is turned to HAND.)

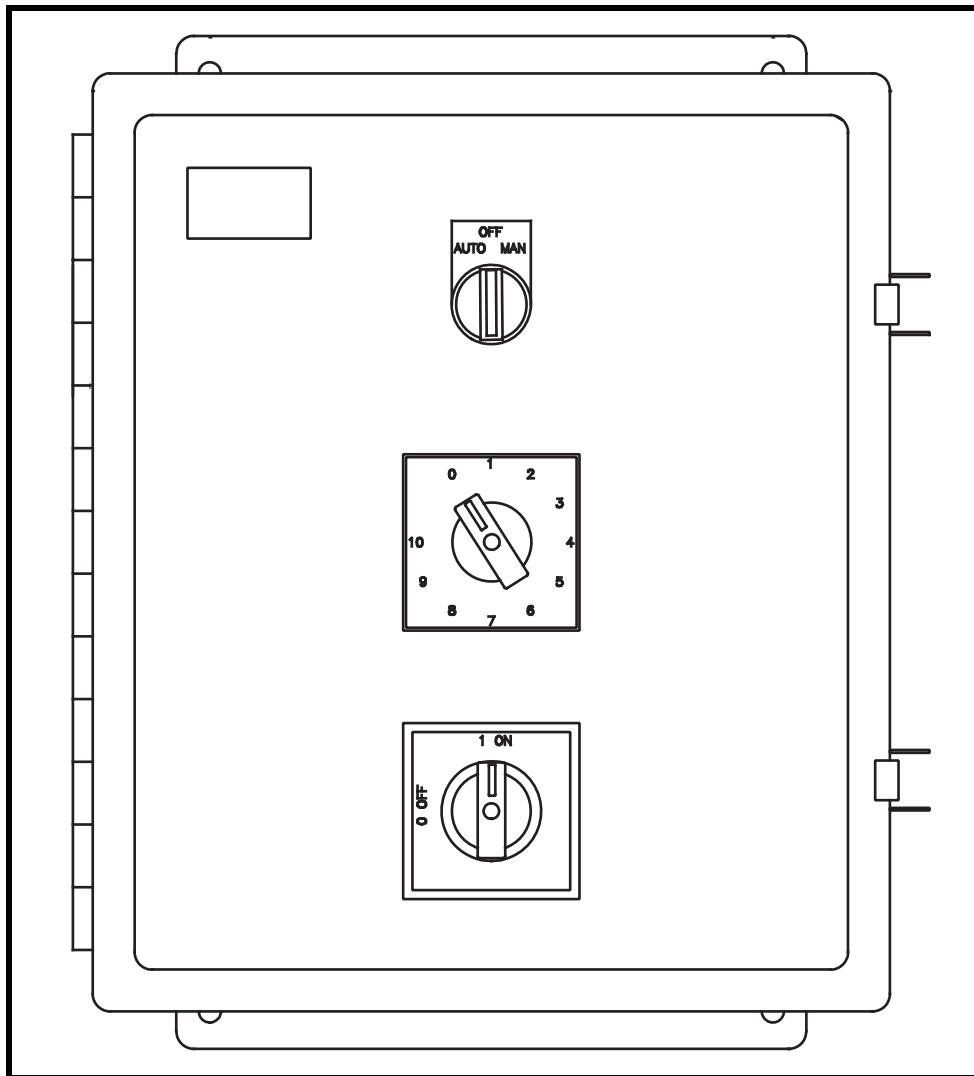

Figure 4. MARTIN® Sonic Horn Controller Door

Programming Controller

NOTE

Before programming the control system, determine the number of sonic horns to be controlled and the off time between cycles.

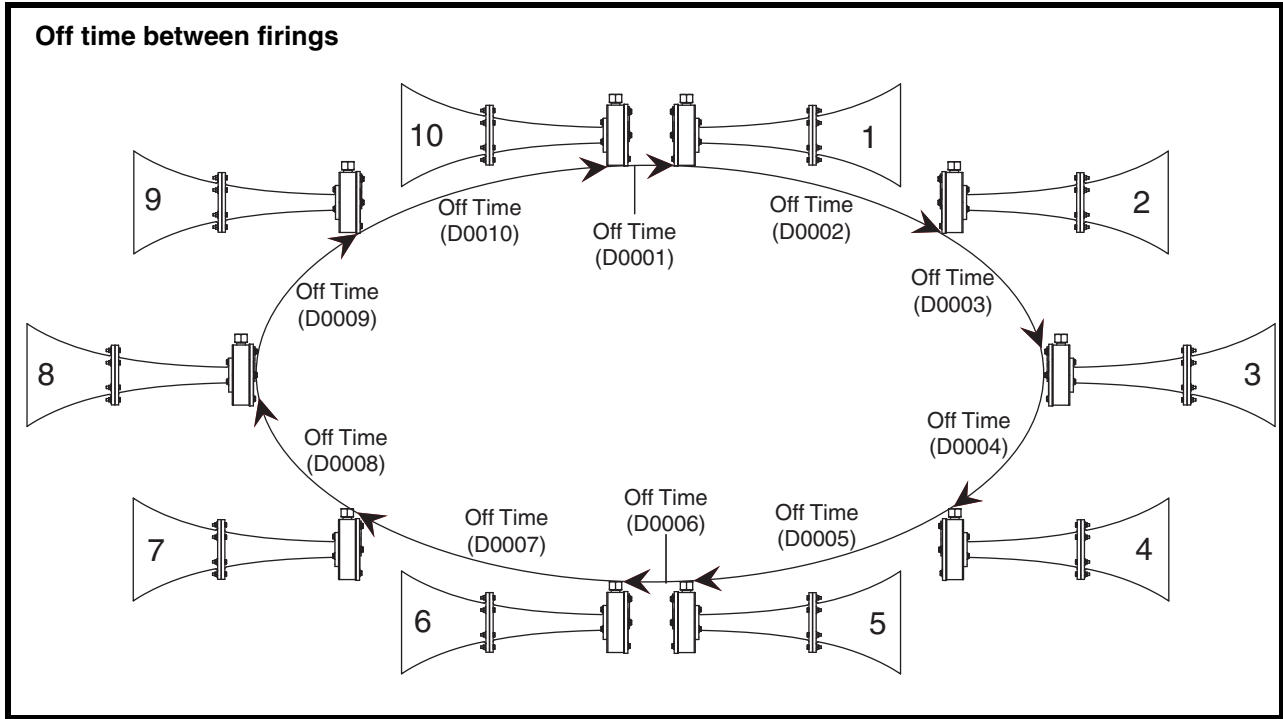
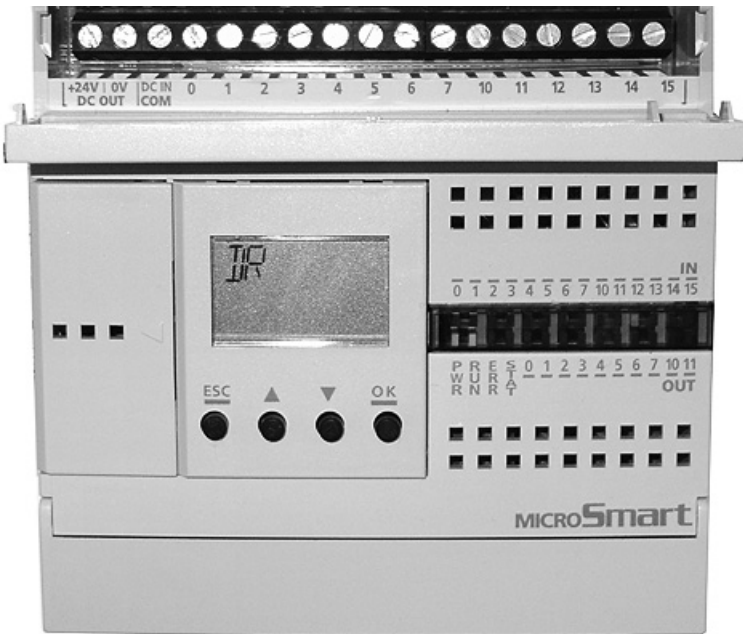

Figure 5. Off Time Selection



Button	Function
ESC	Cancels the current operation, and returns to the immediately preceding operation.
▲	Scrolls up the menu or increments the selected number.
▼	Scrolls down the menu or decrements the selected number.
OK	Goes into each control screen or enters the current operation.

Setting on time

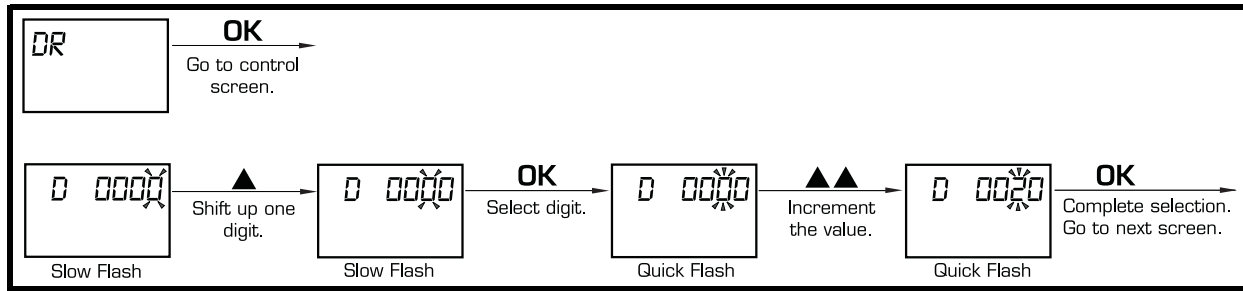

Figure 6. Selecting On Time

1. Scroll to the Data Register Menu (screen with only the letters DR).
2. Follow the steps in Figure 6 to select the on time (20) to be changed.

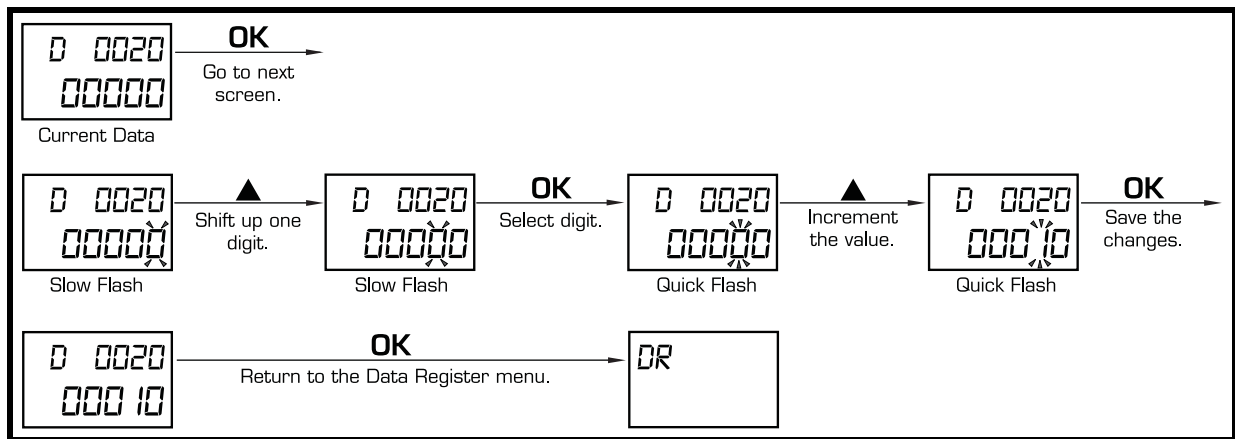

Figure 7. Setting On Time

3. Follow the steps in Figure 7 to input the number of seconds for the on time. The recommended on time is 10 seconds.

Setting off time

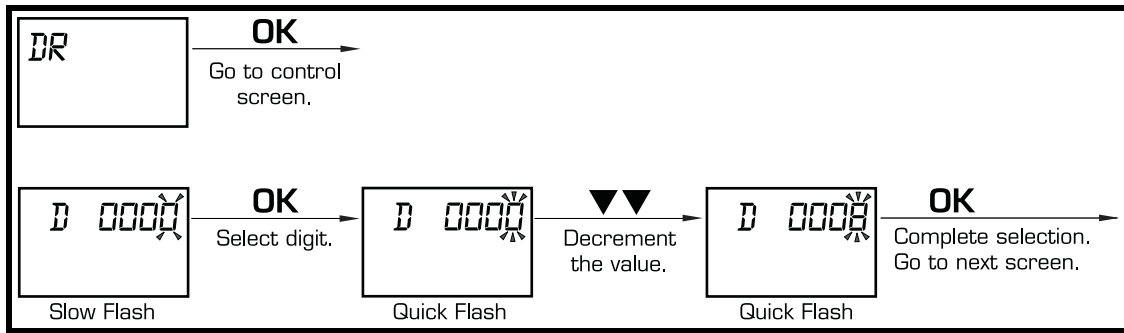

Figure 8. Selecting Off Time

1. Scroll to the Data Register Menu (screen with only the letters DR).
2. Follow the steps in Figure 8 to select the off time (1–10) to be changed.

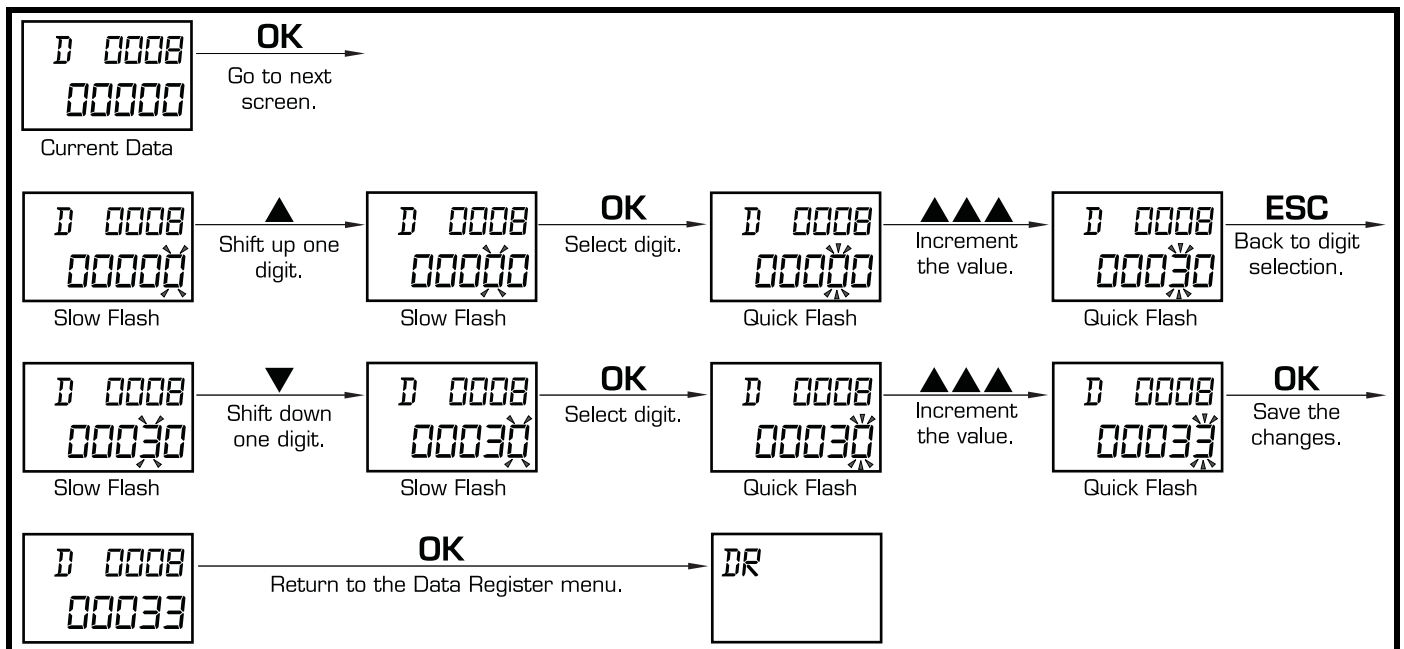

Figure 9. Setting Off Time

3. Follow the steps in Figure 9 to input the number of seconds between sonic horn cycles for the selected off time interval.
4. Repeat procedure for remaining off time intervals.

Parts Numbers

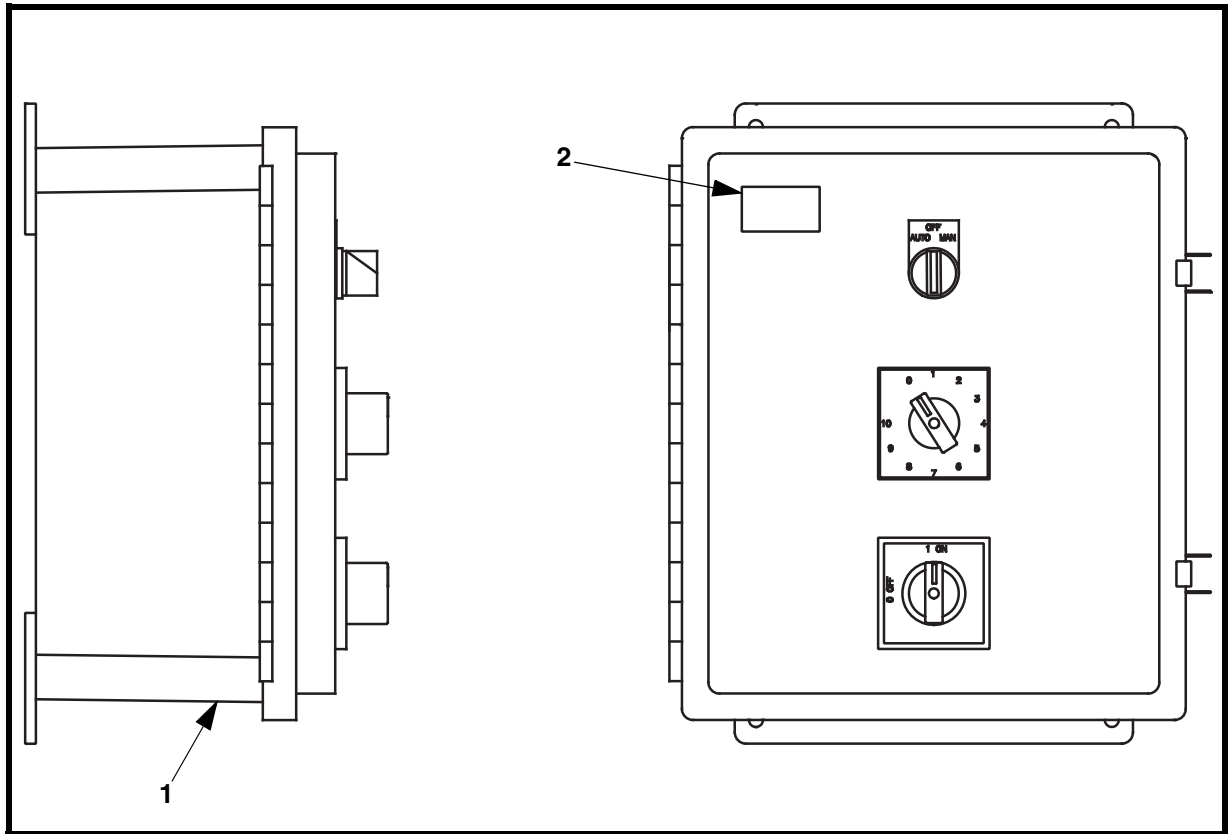
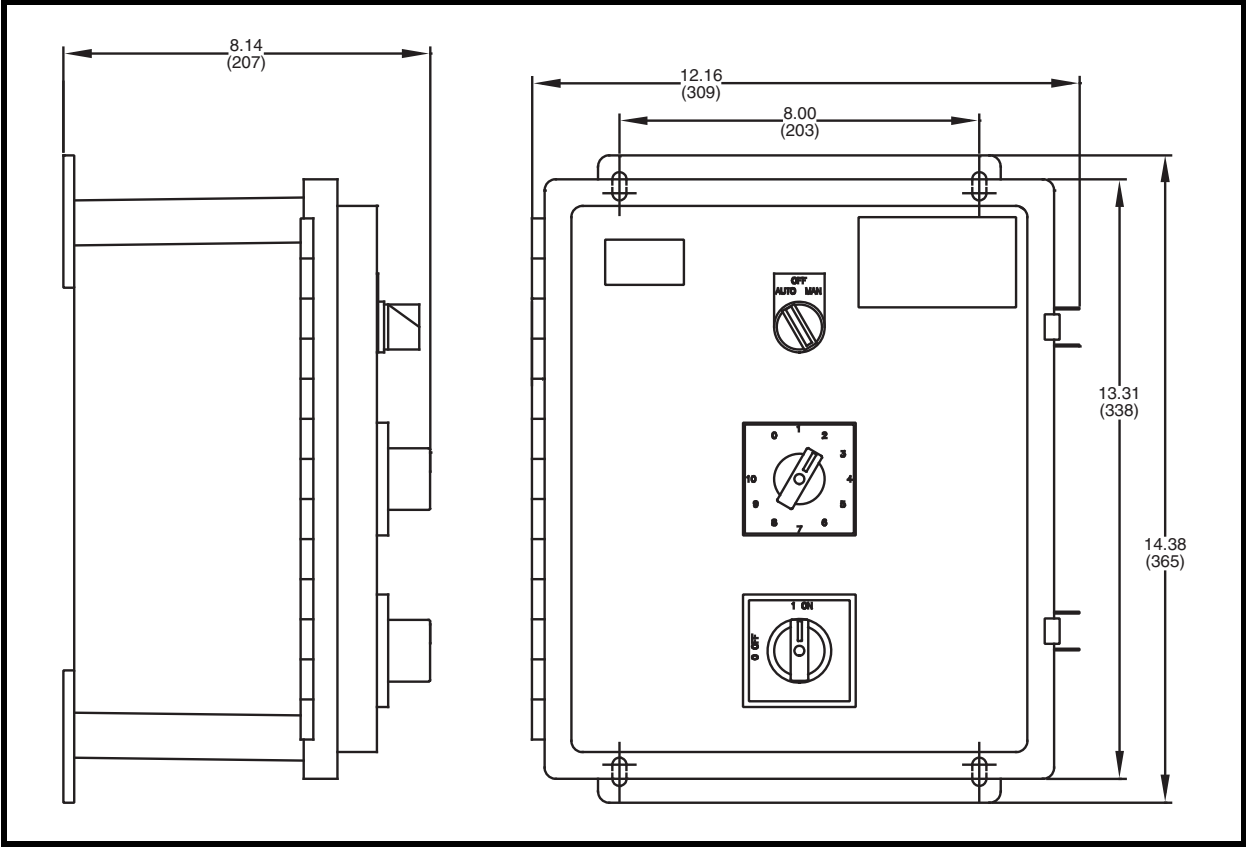

Figure 10. MARTIN® Sonic Horn Controller, P/N 38901-S

Item	Description	Part No.	Qty
1	Sonic Horn Controller NEMA 4	38901-S-01	1
2	Martin Products Label	32238	1
3	Operator Manual	M3859	1



Note: All dimensions are given in inches (mm) and are for reference only.

Figure 11. MARTIN® Sonic Horn Controller Dimensions

Appendix
MARTIN[®] Sonic Horn Controller Electrical Schematic

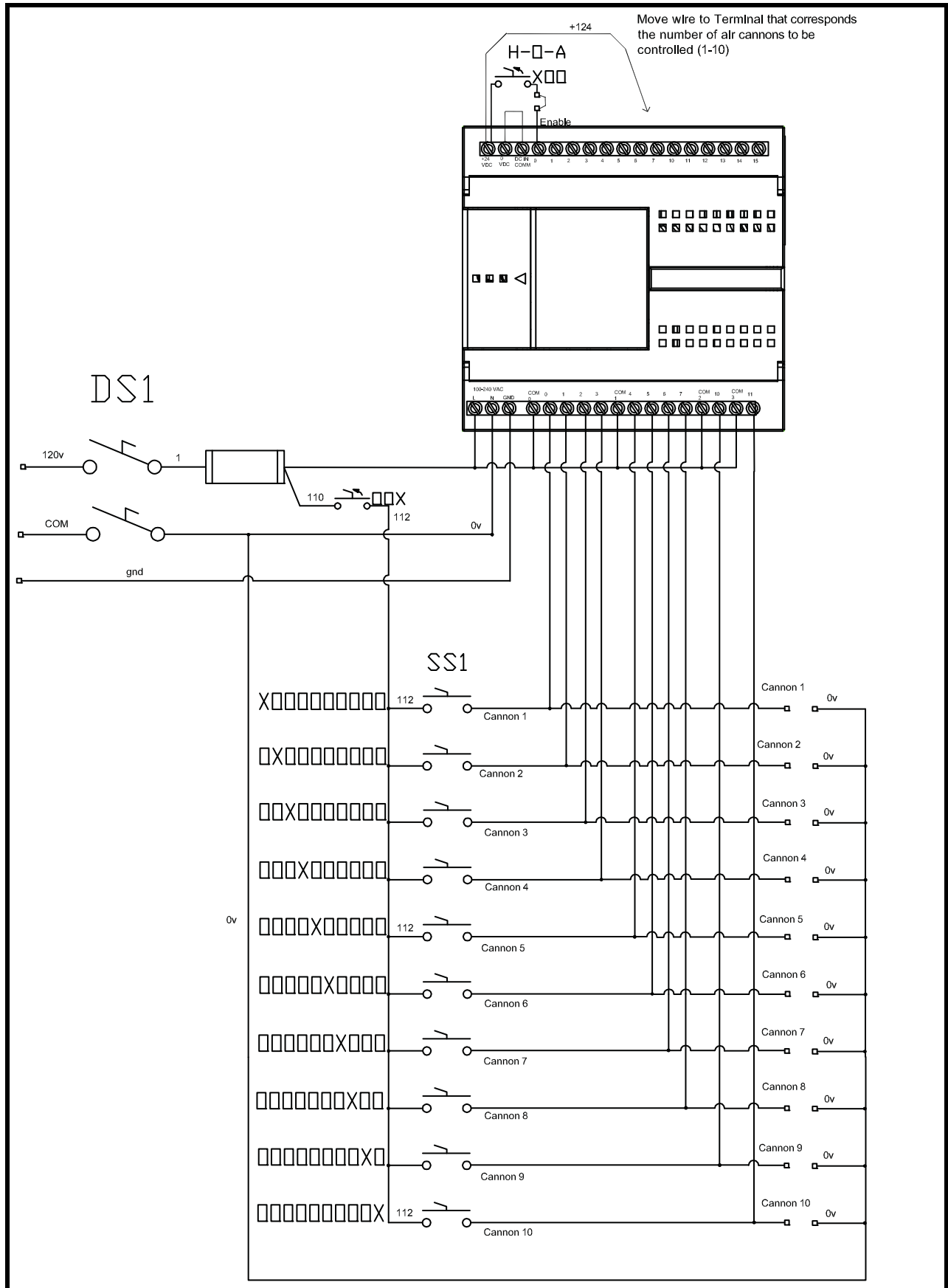

Electrical Schematic

Any product, process, or technology described here may be the subject of intellectual property rights reserved by Martin Engineering Company. Trademarks or service marks designated with the ® symbol are registered with the U.S. Patent and Trademark Office and may be proprietary in one or more countries or regions. Other trademarks and service marks belonging to Martin Engineering Company in the United States and/or other countries or regions may be designated with the “TM” and “SM” symbols. Brands, trademarks, and names of other parties, who may or may not be affiliated with, connected to, or endorsed by Martin Engineering Company, are identified wherever possible. Additional information regarding Martin Engineering Company’s intellectual property can be obtained at www.martin-eng.com/trademarks.

Problem Solved™



Martin Engineering USA

One Martin Place
Neponset, IL 61345-9766 USA
800 544 2947 or 309 852 2384
Fax 800 814 1553
www.martin-eng.com

Subject to change without prior notice.

Quality Management System Certified by DNV - ISO 9001

**QUALITY MANAGEMENT SYSTEM
CERTIFIED BY DNV**

==== ISO 9001:2008 ====